

# VacDry VK3.0S: Specifications

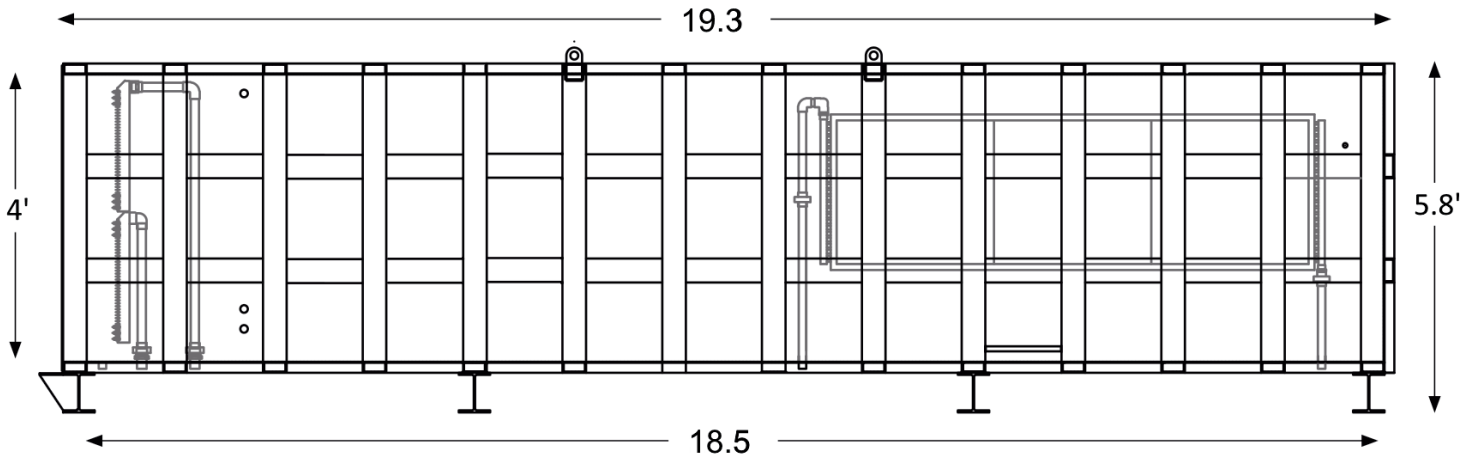

## Projections w/ 8/4 Hard Maple

Layers per Load	16
Max. Boardfeet Capacity	~2341
Boardfeet @ 80% Coverage	~1873
Drying Time	7 Days
Loads per Month	~4
Boardfeet per Month	~7,648
Boardfeet per Year	~91,772

## Requirements w/ 8/4 Hard Maple

Avg Electric Usage per Hour	~4.3 kW
Electric Usage per Load	~724 kW
Electric Cost @ \$0.11/kWh	~\$79
Avg BTU per Hour	~20,841 BTU
MBTU per Load	~3.5 MBTU
BTU Cost @ \$2.70/gal	~\$80

## Specifications

Kiln Charge Size:	50"W x 42"H x 17'L
Floor Space Required:	~6'W x ~38'L
Shipping Weight:	~14,000 Pounds
Service Entrance:	20A @ 460VAC

